

20kW VHF/FM SOLID STATE TRANSMITTER



The 20kW VHF/FM-transmitter T3258 is designed for frequency modulated broadcasts, in mono or stereo, in the VHF frequency range of 87,5 to 108 MHz.

Power classes 2,5 kW, 5 kW, 10kW and 30kW are available in this concept too.

20kW solid state VHF/FM transmitter

Features:

- Solid state design utilizing TMOS FET's (transistors)
- Clearly arranged and easily accessible assemblies mounted in 19" standard racks
- Exciter as synthesizer and control unit with μ P-control
- Serial interface for remote control is standard, BITBUS interface optional
- High redundancy due to modular configuration
- Low junction temperatures ($< 100\text{ }^{\circ}\text{C}$) of the RF power transistors
- Each amplifier disposes of its own switching power supply unit
- Uninterrupted operation even on removal of single amplifiers and power supply units
- Control of mismatch and mains fluctuation via the primary power supply units
- Protective circuits for the RF power transistors providing foldback under high mismatch conditions allow a reliable operation
- High suppression of intermodulation products by using of 90° splitters and 90° combiners
- Efficient low noise forced air cooling
- Variety of intake and outlet solutions for forced air cooling

Set-up:

The 20kW VHF/FM transmitter consists of following assemblies:

- Exciter VHF/FM transmitter T 3270
- 8 x 2.5 kW RF amplifier SV 3254
- 8 x switching power supply unit NG 3254
- Control unit CU 3254 with control panel and central computer

The assemblies are integrated in two racks, dimensioned 2000 x 1200 x 1000 mm (H x W x D).

The transmitter is air cooled. All air in- and outlet lines can be connected either bottom/bottom, bottom/top or top/top.

The distinct switching power supply units assigned to each of the 2.5 kW RF amplifier stages guarantee high redundancy and operational reliability and constitute a well proven concept of our company for years.

Principles of Operation:

The VHF/FM transmitter T 3270 of recent design will be used as exciter. Its performance characteristics determine the quality parameters of the transmitter as a whole.

The exciter power is distributed via a 1:2 splitter and 1:4 splitters to the eight 2.5 kW amplifiers S 3254. In each amplifier the exciter power is routed via a driver amplifier and a 0° splitter to five 500 W amplifiers, which are connected in parallel and are summarized to 2.5 kW output power with a combined 5 :1 combiner-harmonic filter. These 2.5 kW partial powers of each amplifier are paralleled to 10 kW in a multistage 90° combiner. The 10kW blocks are paralleled by a 3 dB coupler to 20kW.

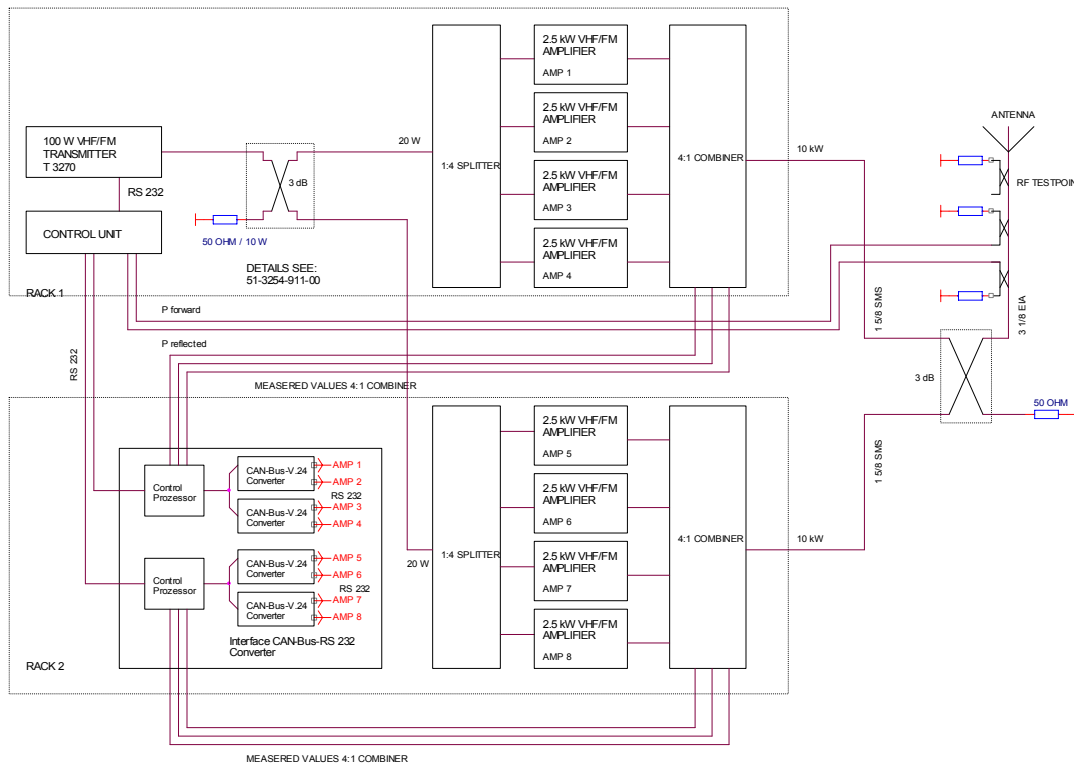

Schematic 20kW VHF/FM transmitter

The directional coupler at the RF output, accommodating forward and reflected coupling loops, serves for RF power indication as well as for transmitter protection functions.

Under high mismatch conditions (VSWR >1.5 : 1) the output power is leveled down (foldback) to an appropriate value not endangering the transistors. Switch off is not initiated. A free RF measuring point is available for measuring purposes. Continued operation at reduced power takes place when power transistors or complete 2.5 kW modules fail.

The control unit CU 3254 serves for the transmitter’s operational, control and monitoring functions. It is microprocessor controlled. Operational conditions are indicated by LEDs and an LCD. For remote control, the control unit incorporates a V.24/RS232C interface or optionally a BITBUS interface.



VHF/FM transmitter T 3270

Technical Data:

Frequency range	87.5 to 108 MHz
RF output	3-1/8"-EIA
RF output power	20 kW
RF output impedance	50 Ω
Harmonic suppression	> 80 dB
Intermodulation products	< 1 μW
Remote control via serial interface	V.24/RS232C
BITBUS interface	optional

Environmental Conditions:

Ambient temperature	performance data guaranteed operational	between – 5...+45°C
	storage	between –10...+55°C
		between –20...+70°C
Humidity	class F according to DIN 40040	≤ 95 %
	annual mean	≤ 75 %
Installation height		≤ 3000 m

Power Supply:

Mains	3/N/PE ~ 400 V	±10 %, 47 to 70 Hz
Power consumption	at 20 kW RF power	≤ 32 kVA (without blowers)
Power factor cos φ		≥ 0.9

Dimensions:

height without blowers	2000 mm
width	1200 mm
depth	1000 mm

The transmitter fulfils the safety regulations for radio transmitters according to DIN VDE 0866 (EN 60215).

The exciter’s technical data are defined in the separate data sheet of transmitter T 3270.

TELEFUNKEN FM Transmitters

a secure investment into the future

Contact: Gerd Barthel, Marketing & Sales
 Telephone +49 30 33978 101
 Telefax +49 30 33978 199
 e mail g.barthel@tsb-ag.com
 Internet http://www.tsb-ag.com